

KF10

Optical system

Melt Pressure & Temperature Sensor

The innovative resin pressure sensor that measures pressure optically.



CE UK CA RoHS

Durability is improved
by the sapphire single
crystal diaphragm!

Achieves high-pressure measurement
of $\pm 0.5\%$ F.S. at 400°C !

High-precision pressure measurement at high temperatures with an optical system!

- **Compatible with high temperatures (400°C)**

This is an optical sensor that does not use semiconductor elements in the detection unit, so high temperature measurement ($\pm 0.5\%$ F.S. at 400°C) is possible.

- **By adopting a sapphire diaphragm, durability performance is improved compared to conventional products**

Compared to metal diaphragms, it has 4.5 times the tensile strength and 10 times the wear resistance.



- **Simultaneous measurement of pressure and temperature**

Simultaneous measurement of pressure and temperature with an optical pressure sensor and a built-in thermocouple.

- **No enclosed liquid structure**

Achieves high accuracy $\pm 0.25\%$ F.S. (at 150 to 300°C) with a safe and secure structure that uses an optical system and does not use an "enclosed liquid" to transmit pressure change.

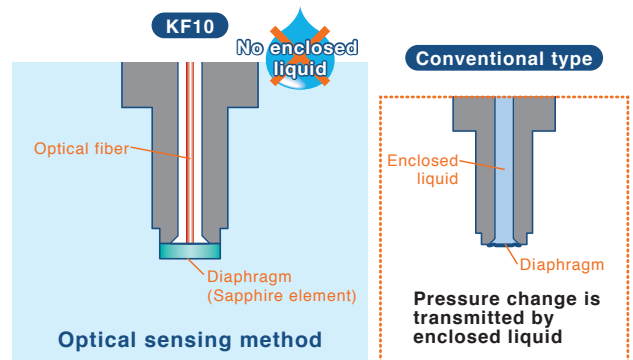

- **Optical pressure sensor configuration diagram**

A gap is provided in the sapphire element, and the gap distance that changes depending on the pressure applied to the diaphragm is directly measured by using the white interference method. Simultaneous temperature measurement is also possible with a thermocouple.

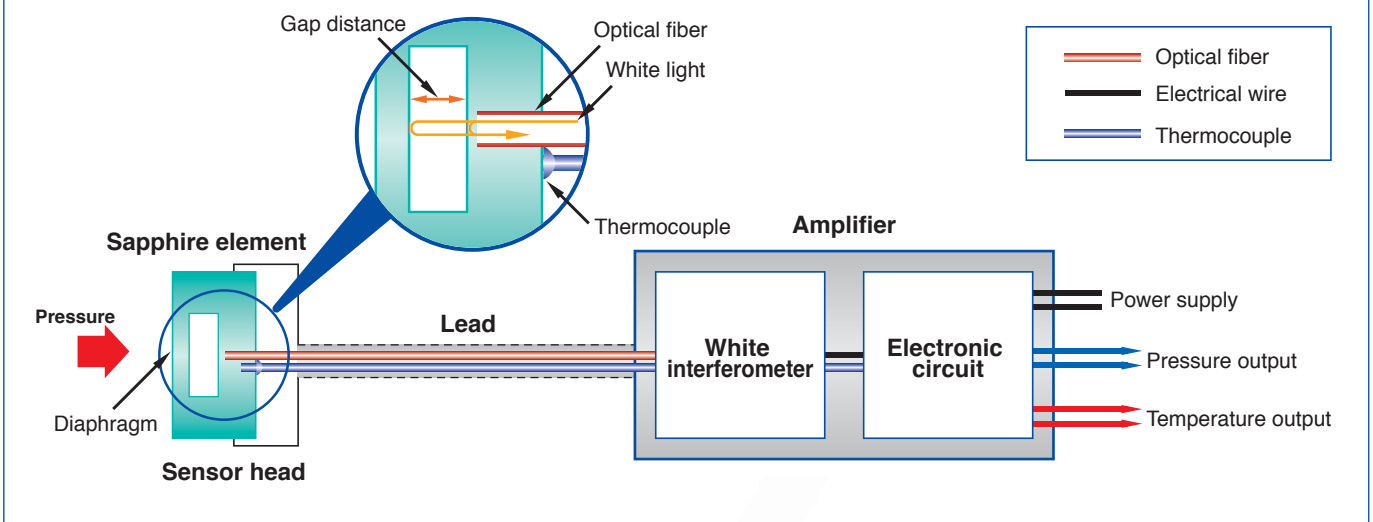

Melt Pressure & Temperature Sensor

Specifications

Items	Description
Wetted parts materials	Sapphire, SUS316, Nickel, Gold-copper alloy, Fe+Ni+Co alloy
Pressure range	0 to 1, 3.5, 10, 25, 35, 50, 70 MPa
Temperature range	0 to 400°C
Diaphragm diameter	φ8 mm
Sensor length (B dimension)	80, 150, 200, 250, 300, 350 mm
Connection*1	G1/4B 1/2-20UNF
Pressure output accuracy*2	0.25% at 150°C (Factory default*3 10MPa range or less is ±0.5%F.S.) 0.5% at 300°C (Factory default*3 10MPa range or less is ±1.0%F.S.)
Temperature coefficient	Detection end: ±0.05% FS/°C (between 150°C and 400°C) Circuit part*4: ±0.05% FS/°C
Temperature output accuracy	±2.5°C (150 to 333°C) 333°C or higher ±0.75% X ITI°C * ITI: Temperature at measurement
Maximum allowable pressure	120%F.S.
Operating temperature	Sensor head: 0 to 400°C Lead: 0 to 150°C Amplifier section: 0 to 60°C
Storage temperature	-20 to 80°C
Lead length	2 m*5
Cable bend radius	80 mm (minimum)
Supply voltage	15 to 30V DC
Current consumption	Max. 250mA
Output	4 to 20mA DC (standard) 0 to 5V DC 0 to 10V DC
Response speed	50 ms
Zero adjustment	Non-contact adjustment with adjustment magnet * Adjustment magnet (1 piece) is included as standard.
Protection class	IP54

*1 Except these sizes, optional adapter , model FJ95 is available (as the size of sensing part is 1/2-20UNF) .

*2 If the temperature is below 150°C, the accuracy is not guaranteed.

*2,4 The temperature at the time of shipping inspection of the circuit part is 30°C.

*3 The reference temperature can be changed by adjusting the zero point at the temperature for use.

*5 The standard lead length is 2 m. The length of the connector cable can be specified separately.

Zero adjustment and output confirmation function (magnet type)

Various operations can be performed without contact by using a magnet.

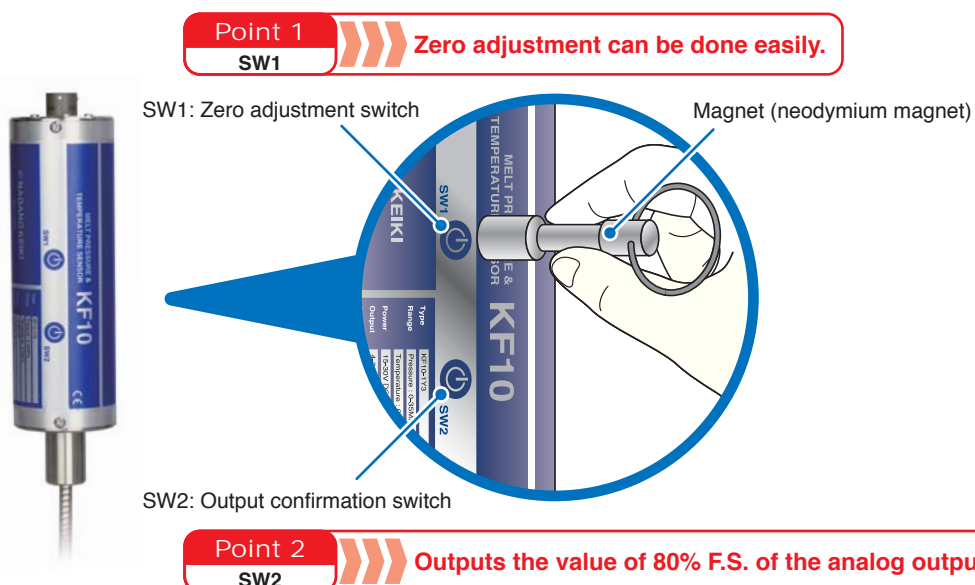

● Application example

Temperature / pressure measurement of extrusion machine

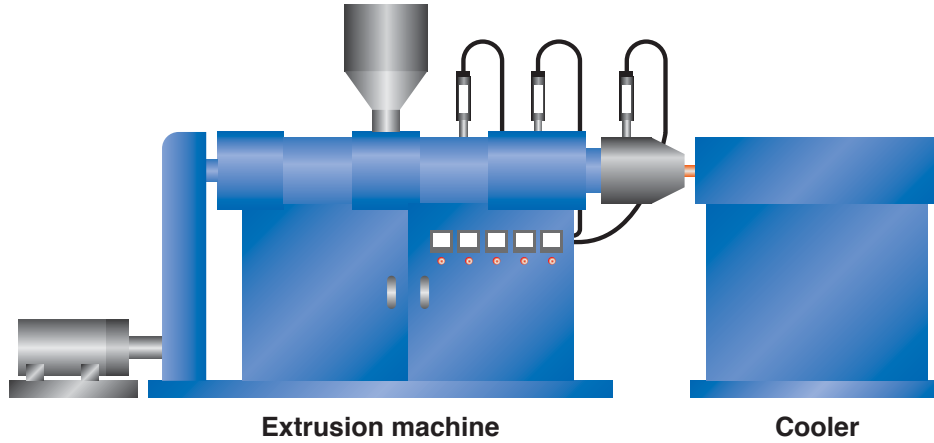

Extrusion machine

Cooler

Dimensions [KF10]

Unit: mm

Sensor head

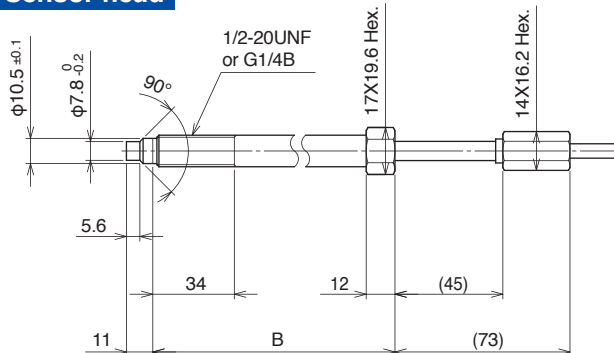

Amplifier

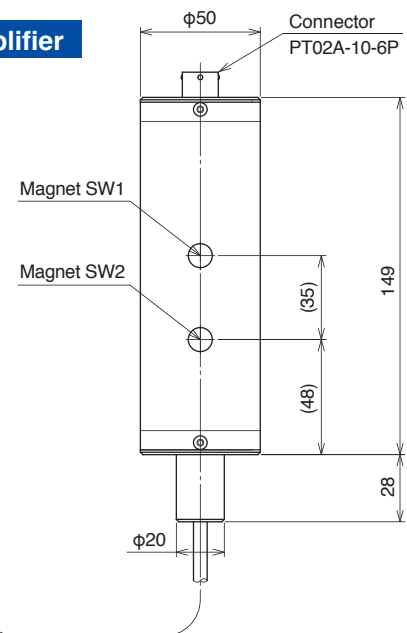

Recommended sensor port dimensions

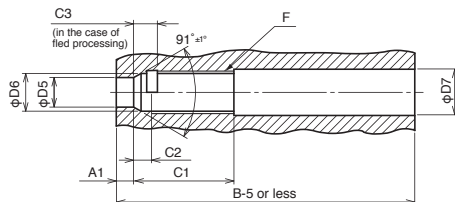

Diaphragm diameter	F	D5	D6	D7	A1	C1	C2	C3
8	G1/4B	7.93 ^{+0.05} ₋₀	11.5 ^{+0.3} ₋₀	13.6 or less	6.4 or less	35 ⁺³	6 or less	9 or less
8	1/2-20UNF	7.93 ^{+0.05} ₋₀	11.5 ^{+0.3} ₋₀	13.1 or less	6.4 or less	35 ⁺³	6 or less	9 or less

Amplifier mounting bracket (option)

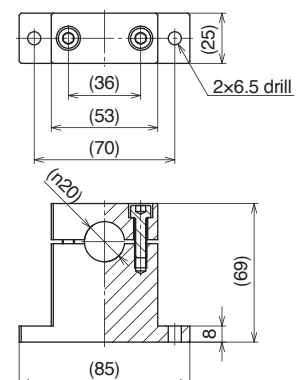

● Electrical connections

Connector terminal array	Terminal number	Power supply/output
	A	Power supply +
	B	Power supply -
	C	Pressure output +
	D	Pressure output -
	E	Temperature output +
	F	Temperature output -

PT02A-10-6P(manufacturer: Amphenol)

Dimensions [FJ95 dedicated adapter/port plug]

Unit: mm

φ18 Gasket seal

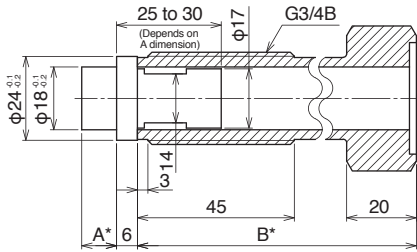

FJ95-263

φ18 Taper seal

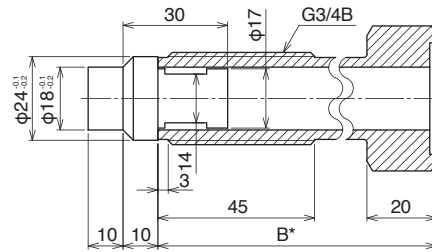

FJ95-563

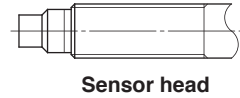

Sensor head

φ23.6 Gasket seal

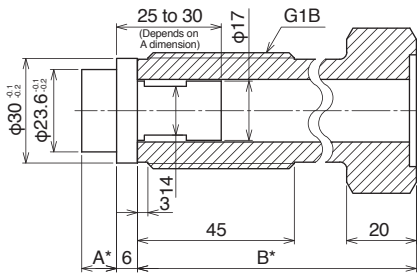

FJ95-383

φ23.6 Taper seal

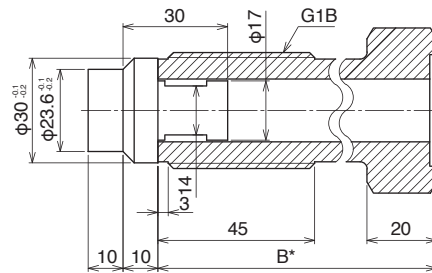

FJ95-683

- * Dimension A Please specify from 10mm to 30mm by 5mm step.
- Dimension B Please specify 55mm or from 80mm to 300mm by 10mm step.

Port plug

- * Used to check the shape of the sensor port and to block the sensor port.
- To prevent damage to the sensor head, it is recommended to check in advance using a port plug before installation.

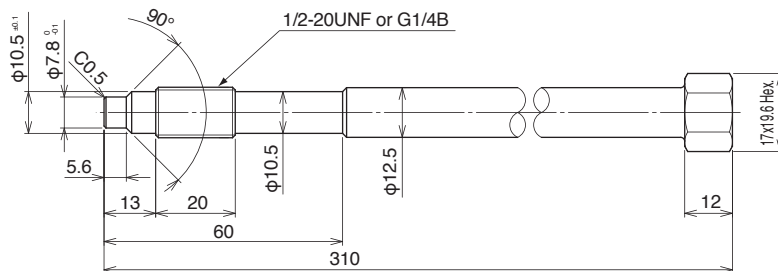

FJ95-8□3

Model number configuration Please specify the model number and each specs for ordering.

Model name

K	F	1	0	—	1	3	—			1		0			×	×	3			
Melt Pressure & Temperature Sensor					①	②	③		④	⑤	⑥	⑦	⑧	⑨	⑩	⑪	⑫	⑬	⑭	⑮

Model number	Selective spec.	Additional spec.
KF10		[Standard specifications] Indoor use Case material: Aluminum alloy Wetted parts material: Sapphire, SUS316, Nickel, Gold-copper alloy, Fe+Ni+Co alloy Diaphragm diameter: φ8 Seal method: Tapered seal Detection unit temperature: 0 to 400°C

①Model	1	Thread connection
②Connection *1	2	G1/4B
	Y	1/2-20UNF

③Wetted parts material	3	Sapphire, SUS316, Nickel, Gold-copper alloy, Fe+Ni+Co alloy
------------------------	----------	---

④Pressure range (MPa)	⑤Accuracy	④Pressure range (MPa)	⑤Accuracy
G	5	0 to 1	±0.5%FS (150°C) / ±1.0%FS (300°C)
K		0 to 3.5	
N		0 to 10	
Q	4	0 to 25	±0.25%FS (150°C) / ±0.5%FS (300°C)
R		0 to 35	
S		0 to 50	
T		0 to 70	

⑥Power source	1	15 to 30V DC
---------------	----------	--------------

⑦Analog output	1	4 to 20mA DC (standard)
	6	0 to 5V DC
	7	0 to 10V DC

⑧Treatment	0	Nil
	1	Use no oil
	2	Use no water
	3	Use no oil & water

⑨Digital output	0	Nil
-----------------	----------	-----

⑩Connector cable length	0	Nil (standard)
	1	2 m
	2	4 m
	3	6 m
	4	8 m
	5	10 m

⑪B dimension	1	80 mm
	2	150 mm
	3	200 mm
	4	250 mm
	5	300 mm
	6	350 mm

⑭Construction	3	Remote type (Lead length 2 m) *2
---------------	----------	----------------------------------

⑮Document	0	Nil
	1	Required

- *1 For non-standard connection sizes, use the separately sold adapter (FJ95).
Select 1/2-20UNF when combined with FJ95.
- *2 The standard lead length is 2 m.
For the length of the connector cable, specify in ⑩.

Optical Pressure Sensors

New measurement technology for "ultra-low to ultra-high temperature" applications!

Mechanical type



Electric type



Nagano Keiki Core technology

Optical system

Optical pressure sensor configuration

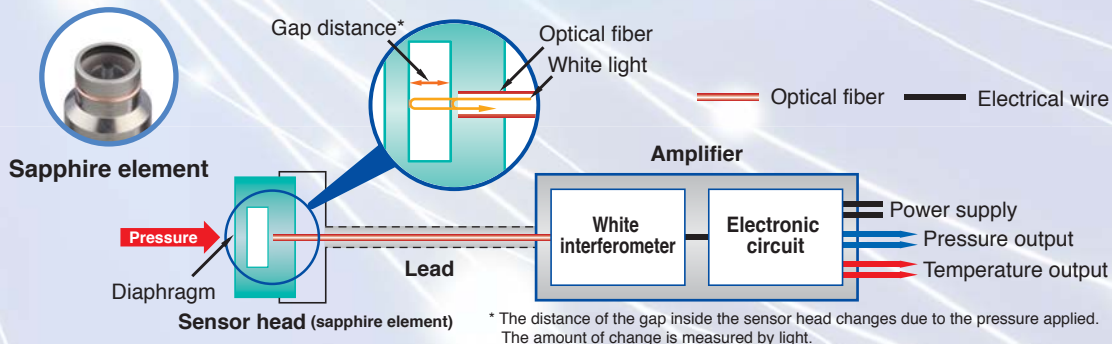

Considering commercialization with optical pressure sensor

KF10 Melt Pressure & Temperature Sensor has been commercialized.

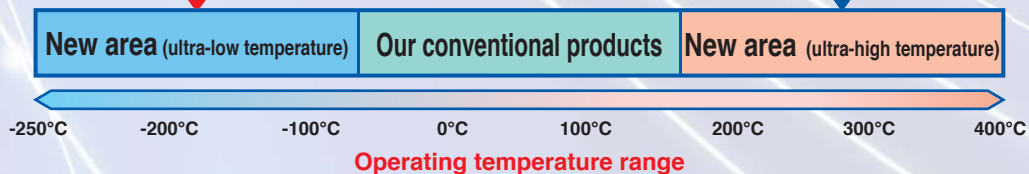

The operating temperature range has been greatly expanded compared to conventional products, making it possible to measure pressure in extreme environments.

The contents in the catalogue are subject to change without notice.

NAGANO KEIKI

NAGANO KEIKI CO., LTD.

URL : <https://www.naganokeiki.co.jp/>

HEAD OFFICE & OVERSEAS SALES DEPT

1-30-4, HIGASIMAGOME OHTA-KU, TOKYO, JAPAN.

PHONE : +81-3-3776-5328 FAX : +81-3-3776-5447

E-mail : overseas_sales_dept@naganokeiki.co.jp